

Tools and Items Needed

- Drill/power screwdriver
- Carriage bolts
- Hammer
- Miter or circular saw with carbide tip blade
- Clear exterior construction adhesive
- Marked speed square
- Tape measure
- Carpenter's level
- Carpenter's pencil
- Adjustable wrench or socket wrench for bolts, etc.
- Safety glasses/goggles
- #1 and #2 square head drill bits
- 1/8" drill bit
- Rubber mallet

For 6' or 8' On-Center Classic Style Line Railing:

One line rail kit (fig. 1a), which contains:

- 1 - Top rail
- 1 - Bottom rail
- 1 - Support block for 6' rail and (2) for 8' rail
- 1 - Classic line rail bracket kit, which contains:
 - 4 - Brackets
 - 4 - Bracket covers
 - Screws
- 13 - 32-1/2" Square Composite Balusters for 6'

Sold Separately:

- 1 - 40" Post sleeve with trim for each railing section (48" post is needed for 42" rail)
 - 1 - Post cap for each post sleeve
 - 1 - 40" Post sleeve with trim to end the railing run (48" post is needed for 42" rail)
- Post sleeve, post cap and trim are not included in rail kit.*

Line Railing Installation Instructions

Prior to construction, check with your local regulatory agency for special code requirements in your area.

Structural support should come from either the continuation of deck support posts that extend up through the deck floor, railing posts that are bolted to the inside of the rim/outer joists or structural post mounts. The post spacing will be less for angled rail applications. Always measure prior to securing the posts when installing angled rail sections. Install railing posts before deck boards are fastened to the joists.

The railing comes pre-routed for balusters. Pre-drilling all other screw holes is essential for successful rail installation. Do not over-tighten screws. **Read instructions completely to get an understanding of how the product goes together and how each piece affects the others.**

Step 1 Determine the number of railing posts needed for your deck. Post spacing is either 6' on-center or 8' on-center depending on the rail length chosen. Example: A 12' x 16' deck attached to a building with a 4' access opening on one side will require a total of eight posts (fig. 2).

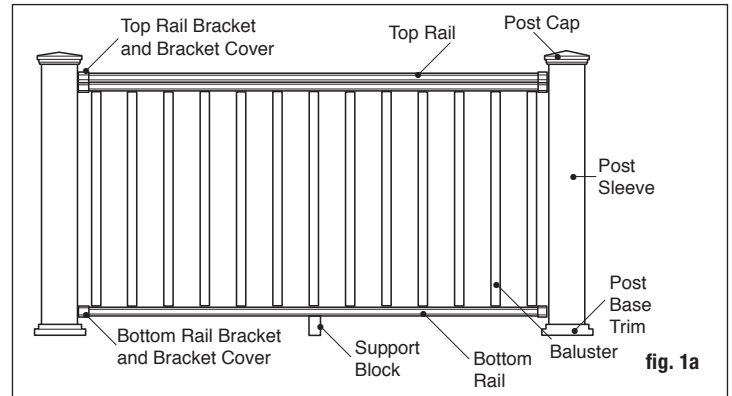

fig. 1a

Classic Style Railing

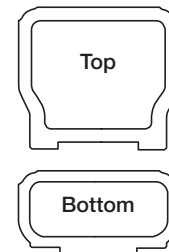

fig. 1b

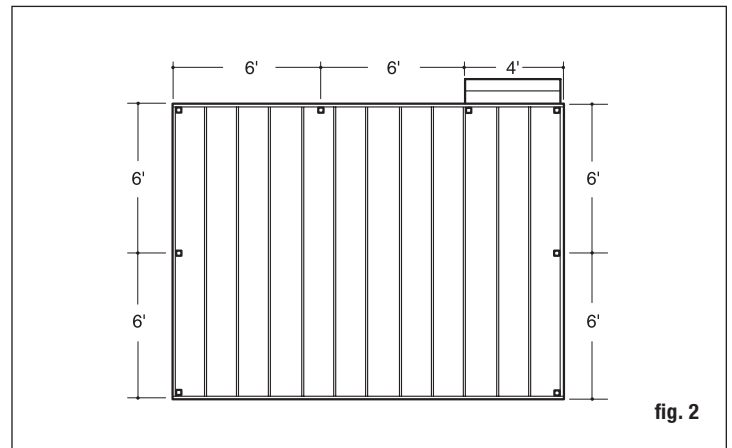

fig. 2

Step 2 Install railing posts prior to installing deck boards. Cedar or pressure-treated pine 4x4 railing posts or a post mount provides the structural strength for the railing. The length of each post is determined by the total of the joist width (typically 7-1/4") + decking thickness (1") + railing height (36") + spacing for post cap (2") = 46-1/4". **Important: Do not notch the 4x4 railing posts. Notching will reduce the strength of the post and could result in railing collapse or failure (fig. 3).** Use structural post mounts for installation on concrete.

Step 3 Position, plumb with a level, and clamp the railing post on the interior face of the joist. Plumb again. The 4x4 railing post should be bolted to the inside of the joist using two 1/2" x 6" galvanized carriage bolts. Corner posts use a third carriage bolt inserted through the adjacent joist (fig. 3).

Step 4 Install decking; notch deck boards to fit around the 4x4 railing posts. Allow 1/4" space between the deck boards and any permanent structure or post. Additional blocking may be necessary on the 4x4 for fastening deck boards.

Step 5 Trim 4x4 post sleeves to length. Post sleeves should be a minimum of 2" longer than the railing height (fig. 4). Example: For a 36" high railing, trim post sleeve to a minimum of 38", can be left longer if desired. Slide a trimmed post sleeve over each 4x4 railing post or post mount. Post sleeve should slide easily over the post. **DO NOT FORCE** post sleeve onto post. Twisted or crooked 4x4s should be replaced. Slide a post base trim (optional) over each post sleeve for a finished look. *Note: It is recommended to install the post base trim prior to installing the bottom rail. However, the two-piece design does allow the installer to add the post base trim after the rail has been installed. To install, apply a thin line of clear exterior construction adhesive to the inside of the post trim, where it will contact the post sleeve, and snap into place around the base of the post sleeve.*

Step 6 Measure the distance between installed post sleeves to determine the length of the top and bottom rails. Place the bottom rail in position next to the posts and adjust so the distance between the first baluster hole and post is greater than 2" and equal on both ends (refer to fig. 5). Mark the rail. Cut the bottom rail. Cut the top rail to the same spacing and length.

Step 7 Find the center of the underside of the bottom rail and attach the baluster connector included with the support block using the screw provided. Check building code requirements for the maximum spacing between deck surface and bottom of rail (sweep); we recommend 3" but it can be less if desired. If necessary, trim the support block to the determined height (fig. 6).

Drill two 1/4" drain holes through the bottom of the rail to prevent trapping water. Center drain holes between two baluster locations as baluster can block the pathway and stop water from properly draining.

Step 8 Place the line rail bracket covers and line brackets on the ends of the bottom rail. Install the support block and prop the bottom rail between the posts using blocks cut to size. Check the rail for level. Using the line bracket as a guide, mark the screw positions on the post sleeve and rail on both ends. Pre-drill 1/8" pilot holes through the post sleeve and rail. Attach the line bracket to the post sleeve using the #8-15 x 2" - #2 square drive pan head screws and then attach line bracket to rail using #10-16 x 3/4" - #2 square drive pan head self-drilling screws.

Step 9 Place balusters into each routed hole in the bottom rail. Make sure balusters are fully seated in rail.

Step 10 Place the line rail bracket covers and line brackets on the ends of the top rail. Position the top rail by placing the balusters inside the routed holes, while working from one end to the other. Check the rail for level. Using the line bracket as a guide, mark the screw positions on the post sleeve and rail on both ends. Pre-drill 1/8" pilot holes through the post sleeve and rail. Attach the line bracket to the post sleeve using the #8-15 x 2" - #2 square drive pan head screws and then attach line bracket to rail using #10-16 x 3/4" - #2 square drive pan head self-drilling screws (fig. 5).

Step 11 Slide the rail bracket covers over the rail brackets and snap into place.

Step 12 Apply a thin line of clear exterior construction adhesive to the inside rim of a post cap and place firmly on the post. Repeat for each post.

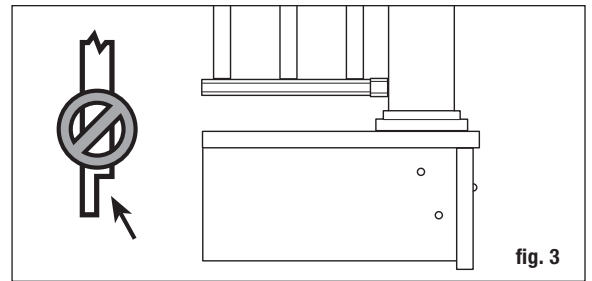

fig. 3

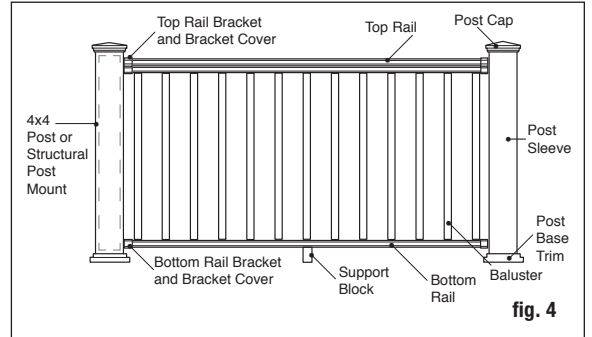

fig. 4

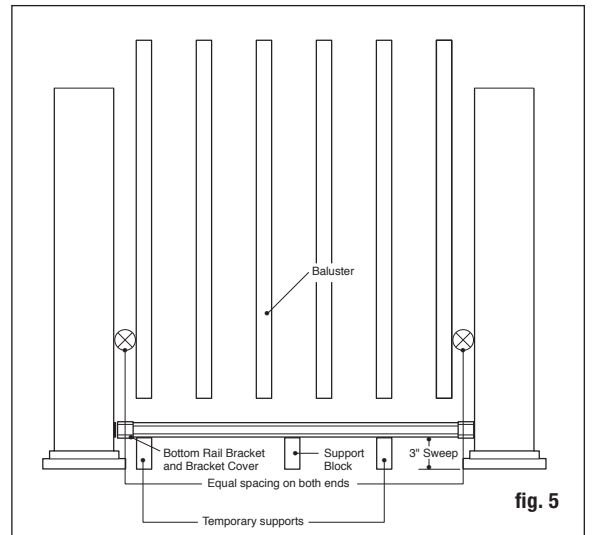

fig. 5

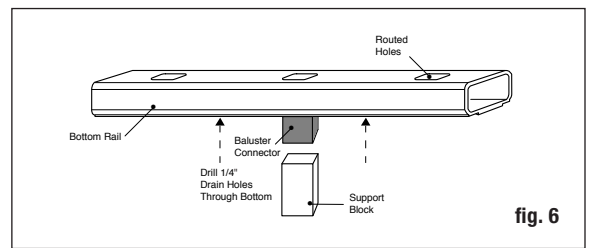

fig. 6

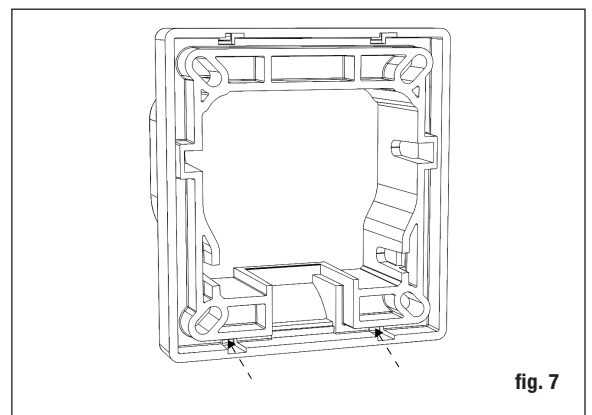

fig. 7

Tip: To separate the bracket cover from the bracket prior to installation, use a small flat head screwdriver to unlatch the lower tabs.

For 6' On-Center Classic Style Stair Railing:

One stair rail kit (fig. 1a), which contains:

- 1 - Top rail
- 1 - Bottom rail
- 1 - Support block
- 1 - Classic stair rail bracket kit, which contains:
 - 4 - Brackets
 - 4 - Bracket covers
 - Screws
- 11 - 32-1/2" Square Composite Balusters for 6'

Sold Separately:

- 1 - 48" Post sleeve with trim for each railing section (54" post is needed for 42" rail)
 - 1 - Post cap for each post sleeve
 - 1 - 48" Post sleeve with trim to end the railing run (54" post is needed for 42" rail)
- Post sleeve, post cap and trim are not included in rail kit.*

Stair Railing Installation Instructions

Note: Stair angle must be between 30 and 35 degrees for brackets in kit to fit properly.

Step 1 Determine the number of stair railing posts needed for your deck. Post spacing is 6' on-center.

Step 2 Install stair railing posts prior to installing stair treads. Cedar or pressure-treated pine 4x4 railing posts or a post mount provides the structural strength for the stair railing. The length of each post is determined by the total of the stringer width + tread thickness + stair railing height + spacing for post cap.

Important: Do not notch the 4x4 railing posts. Notching will reduce the strength of the post and could result in railing collapse or failure (fig. 3). Use structural post mounts for installations on concrete.

Step 3 Position, plumb with a level, and clamp the stair railing post on the interior face of the stringer. Plumb again. The 4x4 stair railing post should be bolted to the inside of the stringer using two 1/2"x6" galvanized carriage bolts. Corner posts use a third carriage bolt inserted through the adjacent joist. Ground level posts should be set in concrete.

Step 4 Install treads; notch treads to fit around the 4x4 stair railing posts. Allow 1/4" space between the treads and any permanent structure or post. Additional blocking may be necessary on the 4x4 for fastening treads.

Step 5 Trim 4x4 post sleeves to length. Post sleeves should be a minimum of 1-1/2" longer than the railing height. Stair posts may be longer to allow for the riser height. Slide a trimmed post sleeve over each 4x4 railing post or post mount. Post sleeve should slide easily over the post. DO NOT FORCE post sleeve onto post. Twisted or crooked 4x4s should be replaced. Slide a post base trim over each post sleeve for a finished look. *Note: It is recommended to install the post base trim prior to installing the bottom rail. However, the two-piece design does allow the installer to add the post base trim after the rail has been installed. To install, apply a thin line of clear exterior construction adhesive to the inside of the post trim, where it will contact the post sleeve, and snap into place around the base of the post sleeve.*

Step 6 Measure the distance between installed post sleeves to determine the length of the top and bottom rails. Ensure baluster holes are oriented in the right direction. Then place the bottom rail on the stair treads next to the posts and adjust so the distance between the first baluster hole and post is greater than 2-3/4" minimum and equal on both ends (fig. 8). Mark the rail to the proper length and angle. Cut the bottom rail. Cut the top rail to the same length and angle (fig. 9). **Drill one 1/4" drain hole through the bottom of the rail to prevent trapping water. Position the hole toward the lower end of the rail, roughly 2.5" from rail end to avoid the lower bracket.**

Step 7 Place the proper rail bracket covers and stair brackets on the ends of the bottom rail. Pay particular attention to the brackets being used as they differ based on top/bottom rail and up/down angle. Determine the position of the support block and attach to the bottom rail. Prop the bottom rail between the

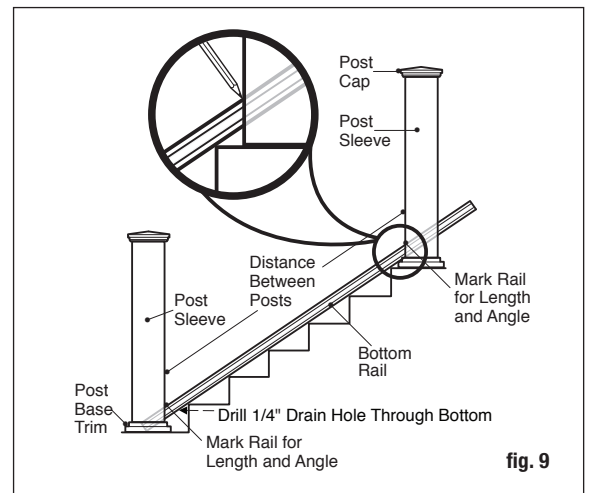
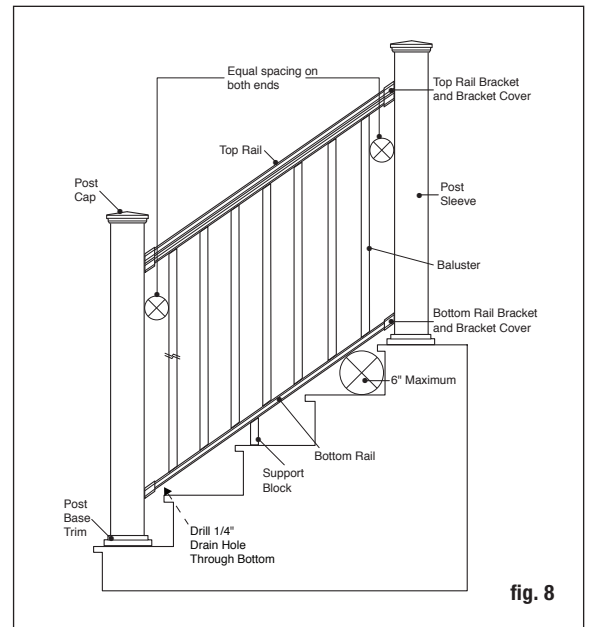

posts on the stair treads (fig. 9). You may need to place equal shims between two stair tread noses to elevate the bottom rail. Check for requirements in your area. Typically, a 6" sphere may not be allowed to pass through the triangle formed by the bottom rail, tread and riser (fig. 8). Center the stair bracket on the post. Using the stair bracket as a guide, mark the screw positions on the post sleeve and rail on both ends. Pre-drill 1/8" pilot holes through the post sleeve and rail. Attach the stair bracket to the post sleeve using the #8-15 x 2" - #2 square drive flat head screws and then attach stair bracket to rail using #8-16 x 3/4" - #1 square drive wafer head self-drilling screws.

Step 8 Place a baluster into each routed hole in the bottom rail. Make sure baluster is fully seated in rail (fig 10).

Step 9 Place the stair rail bracket covers and stair brackets on the ends of the top rail. Position the top rail by placing the balusters inside the routed holes, while working from one end to the other. Center the stair bracket on the post. Using the stair bracket as a guide, mark the screw positions on the post sleeve and rail on both ends. Pre-drill 1/8" pilot holes through the post sleeve and rail. Attach the stair bracket to the post sleeve using the #8-15 x 2" - #2 square drive flat head screws and then attach stair bracket to rail using #8-16 x 3/4" - #1 square drive wafer head self-drilling screws.

Step 10 Slide the rail bracket cover over the rail bracket and snap into place.

Step 11 Apply a thin line of clear exterior construction adhesive to the inside rim of a post cap and place firmly on the post. Repeat for each post.

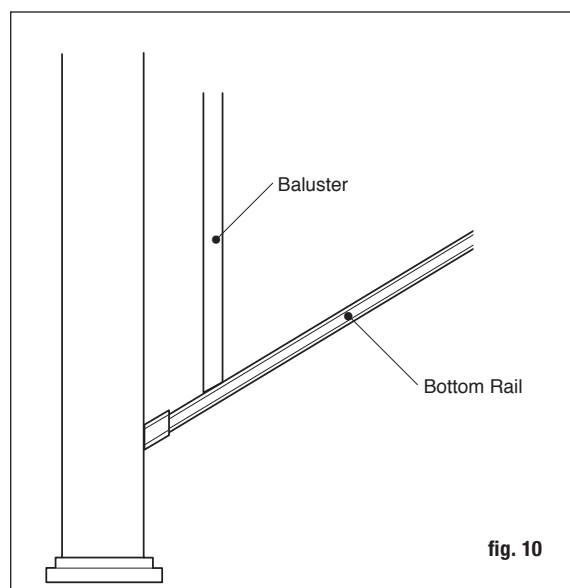

THE DIAGRAMS AND INSTRUCTIONS IN THIS BROCHURE ARE FOR ILLUSTRATION PURPOSES ONLY AND ARE NOT MEANT TO REPLACE A LICENSED PROFESSIONAL. ANY CONSTRUCTION OR USE OF THE PRODUCT MUST BE IN ACCORDANCE WITH ALL LOCAL ZONING AND/OR BUILDING CODES. THE CONSUMER ASSUMES ALL RISKS AND LIABILITY ASSOCIATED WITH THE CONSTRUCTION OR USE OF THIS PRODUCT. THE CONSUMER OR CONTRACTOR SHOULD TAKE ALL NECESSARY STEPS TO ENSURE THE SAFETY OF EVERYONE INVOLVED IN THE PROJECT, INCLUDING, BUT NOT LIMITED TO, WEARING THE APPROPRIATE SAFETY EQUIPMENT. EXCEPT AS CONTAINED IN THE WRITTEN LIMITED WARRANTY, THE WARRANTOR DOES NOT PROVIDE ANY OTHER WARRANTY, EITHER EXPRESS OR IMPLIED, AND SHALL NOT BE LIABLE FOR ANY DAMAGES, INCLUDING CONSEQUENTIAL DAMAGES.